

## Integrated Multi-Channel DC-DC Converters for EPD

### Description

The FP9931 offers a compact power supply solution to provide all voltages required by EPD panel. The FP9931 includes 2 high performance DC-DC converters, one is for positive voltage and the other is for negative voltage used by EPD drivers, a VCOM buffer (unity-gain OPA), a positive charge pump and a negative charge pump to provide adjustable regulated output voltages.

The converters provide the regulated positive and negative supply voltage for the panel source driver ICs.

The positive charge pump controller provides regulated EPD gate-on voltage. The negative charge pump controller provides regulated EPD gate-off voltage.

Accurate back-plane biasing is provided by a linear amplifier and can be adjusted either by an external resistor or the I<sup>2</sup>C interface. The VCOM driver can source or sink current depending on panel condition. For automatic VCOM adjustment in production line, VCOM can be set from 0V to -5V with 8 bit control through the serial interface.

The FP9931 provides precise temperature measurement function to monitor the panel temperature during operation.

### Pin Assignments

WD Package: TQFN-40L (5mmx5mm)

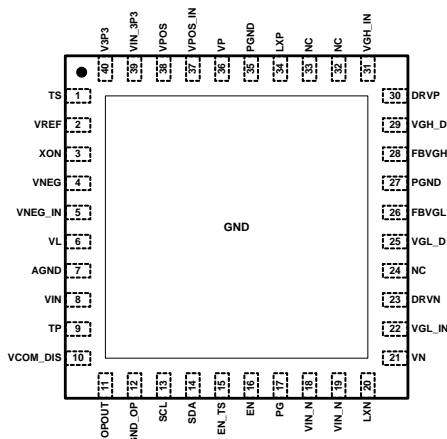

Figure 1. Pin Assignment of FP9931

### Features

- 2.9V to 5.5V Input Supply Voltage
- +7.04V ~ +15.06V Adjustable Output for VPOS
  - ◆ Maximum Output Current 320mA
  - ◆ Current Limit 350mA
  - ◆ Output Under Voltage and Short Circuit Protection
- -7.04V ~ -15.06V Adjustable Output for VNEG
  - ◆ Maximum Output Current 320mA
  - ◆ Current Limit 350mA
  - ◆ Output Under Voltage and Short Circuit Protection
- 0V ~ -5V Adjustable VCOM Output Voltage with 8-bits DAC
- VGH Charge Pump Output from +15V to +30V with External Dividual Resistor
- VGL Charge Pump Output from -15V to -25V with External Dividual Resistor
- Adjustable Soft-start Time from 3ms to 6ms
- Power Good Signal
- Over Temperature Protection
- TQFN-40L (5mmx5mm) Package
- RoHS Compliant
- Thermistor Monitoring
  - ◆ -10°C to +85°C Temperature Range
  - ◆ ±1°C Accuracy from 0°C to 45°C (IC=25°C)
  - ◆ Enable/Disable by EN\_TS

### Applications

- Electro-Phoretic Display (EPD) Panel
- E-Book Readers

### Ordering Information

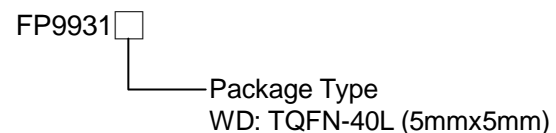

## Block Diagram & Typical Application Circuit

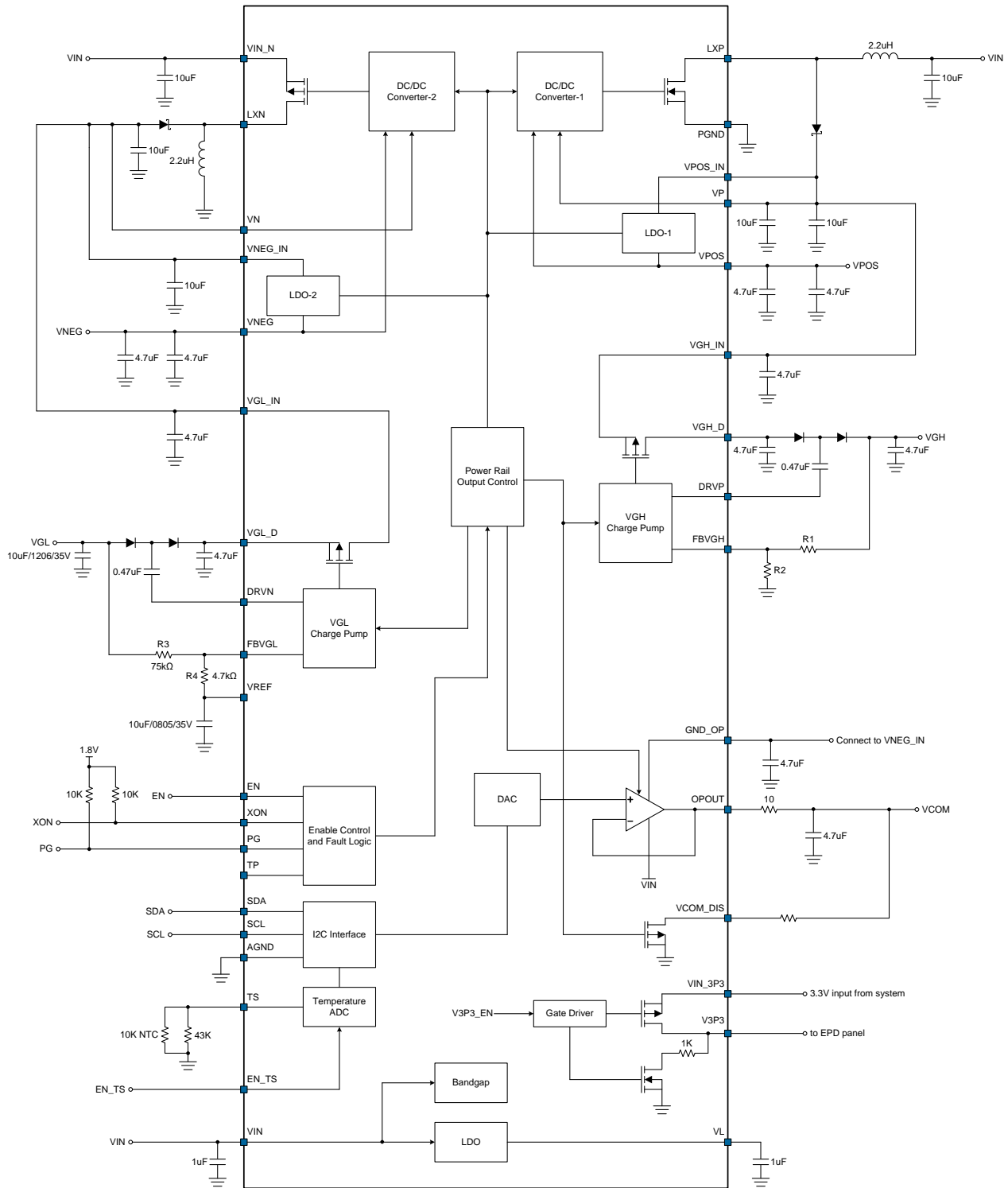

Figure 2. Typical Application Circuit of FP9931

## Functional Pin Description

Pin Name	Pin No	Pin Function
TS	1	Thermistor input pin. Connect a 10K NTC thermistor and a 43K linearization resistor between this pin and system GND.
VREF	2	Internal reference voltage output.
XON	3	NC.Floating.
VNEG	4	VNEG LDO output.
VNEG_IN	5	VNEG LDO input.
VL	6	Internal 5V LDO output.
AGND	7	Analog ground.
VIN	8	Power supply input for PMIC control logic.
TP	9	Test pin for testing, please do not connect to any signal.
VCOM_DIS	10	VCOM OPA discharge open drain Power MOS input.
OPOUT	11	VCOM OPA output.
GND_OP	12	VCOM OPA negative supply input.
SCL	13	Serial interface (I2C) clock input.
SDA	14	Serial interface (I2C) data input/output
EN_TS	15	Temperature ADC enable/disable control.
EN	16	PMIC enable/disable control.
PG	17	PMIC power good signal for system.
VIN_N	18, 19	Source of the internal Power MOS for Buck-Boost converter.
LXN	20	Drain of the internal Power MOS for Buck-Boost converter.
VN	21	Buck-Boost converter output.
VGL_IN	22	Power switching input for VGL supply voltage.
DRVN	23	Switching pin for the negative charge pump.
NC	24, 32, 33	Not connect.
VGL_D	25	Power switching output for VGL supply voltage.
FBVGL	26	Negative charge pump feedback input.
PGND	27, 35	Power ground.
FBVGH	28	Positive charge pump feedback input.
VGH_D	29	Power switching output for VGH supply voltage.
DRVP	30	Switching pin for the positive charge pump.
VGH_IN	31	Power switching input for VGH supply voltage.

## Functional Pin Description (Continued)

Pin Name	Pin No	Pin Function
LXP	34	Drain of the internal Power MOS for Boost converter.
VP	36	Boost converter output.
VPOS_IN	37	VPOS LDO input.
VPOS	38	VPOS LDO output.
VIN_3P3	39	Power switching input from system. (detail refer V3P3 power switch in application information section)
V3P3	40	Power switching output for EPD panel.
Thermal Pad	--	Power ground.

## Absolute Maximum Ratings

- VIN, V3P3, VIN\_3P3, VIN\_N, VREF, VL to GND ----- -0.3V to +6V
- PG, EN\_TS, EN, SDA, SCL, FBVGL, FBVGH, TP, TS to AGND ----- -0.3V to +6V
- LXN to GND ----- -30V to +0.3V
- LXP to GND ----- -0.3V to +24V
- VENG, VNEG\_IN, GND\_OP, VGL\_IN, VGL\_D, VN to GND ----- -22V to +0.3V
- DRVN, DRVP, VGH\_D, VGH\_IN, VP, VPOS\_IN, VPOS to GND ----- -0.3V to +22V
- OPOUT, VCOM\_DIS to GND ----- -6V to +0.3V
- Continuous Power Dissipation ( $T_A=+25^\circ\text{C}$ ) ----- 2.76W
- Package Thermal
  - TQFN-40L (5mmx5mm)  $\theta_{JA}$  ----- 45.3°C/W
  - TQFN-40L (5mmx5mm)  $\theta_{JC}$  ----- 16.1°C/W
- Junction Temperature ----- +150°C
- Storage Temperature Range ----- -65°C to +150°C
- Lead Temperature (Soldering, 10sec) ----- +260°C
- ESD Susceptibility
  - HBM (Human Body Mode): ----- +2KV
  - MM (Machine Mode): ----- +200V

## Recommended Operating Conditions

- Supply Voltage (VIN) ----- +2.9V to +5.5V
- Operating Junction Temperature Range ----- -40°C to +85°C

## Electrical Characteristics

( $V_{IN}=3.7V$ , typical values are at  $T_A=25^{\circ}C$ , unless otherwise specified.)

Parameter	Symbol	Conditions	Min	Typ	Max	Unit
<b>Input</b>						
Input Voltage Range	$V_{IN}$		2.9	--	5.5	V
VIN UVLO Threshold	$V_{UVLO}$	$V_{IN}$ Rising	--	2.7	--	V
		Hysteresis	--	0.2	--	
VIN Supply Current	$I_{IN}$	EN=High	--	1.5	--	mA
VIN Shutdown Current	$I_{SD}$	EN=Low	--	0.1	1	$\mu A$
VREF Output Voltage	$V_{VREF}$		1.225	1.25	1.275	V
VL Output Voltage	$V_{VL}$		--	5	--	V
EN Input High Level	$V_{IH\_EN}$		1.2	--	--	V
EN Input Low Level	$V_{IL\_EN}$		--	--	0.4	V
EN Pull-low Resistor	$R_{EN}$		--	1	--	$M\Omega$
V3P3 Switch MOS On-Resistance	$R_{ON\_V3P3}$		--	10	--	$\Omega$
Thermal Shutdown Threshold	$T_{SD}$		--	140	--	$^{\circ}C$
<b>VP Boost Converter</b>						
LXP Switching Frequency	$F_{LXP}$		--	1	--	MHz
N-MOS On-Resistance	$R_{ON\_LXP}$		--	0.15	--	$\Omega$
LXP Current Limit	$I_{LXP\_OCP}$	Sets by VP_CL	3.5	--	5	A
LXP Current Limit Accuracy	$I_{LXP\_OCP\_A}$		-20	--	+20	%
VP Soft-start Time	$t_{SS\_VP}$	Sets by SS_TIME	3	--	6	ms
Output Under Voltage Protection	$V_{VP\_UVP}$		--	80%	--	VP
Output Under Voltage Protection Delay Time	$t_{VP\_UVP}$		--	40	--	ms
Output Short Circuit Protection	$V_{VP\_SCP}$		--	40%	--	VP
Output Short Circuit Protection Delay Time	$t_{VP\_SCP}$		--	20	--	$\mu s$
<b>VN Buck-Boost Converter</b>						
LXN Switching Frequency	$F_{LXN}$		--	1	--	MHz
P-MOS On-Resistance	$R_{ON\_LXN}$		--	0.15	--	$\Omega$
LXN Current Limit	$I_{LXN\_OCP}$	Sets by VN_CL	3.5	--	5	A
LXN Current Limit Accuracy	$I_{LXN\_OCP\_A}$		-20	--	+20	%

## Electrical Characteristics (Continued)

(VIN=3.7V, typical values are at TA=25°C, unless otherwise specified.)

Parameter	Symbol	Conditions	Min	Typ	Max	Unit
VN Soft-start Time	t <sub>SS_VN</sub>	Sets by SS_TIME	3	--	6	ms
Output Under Voltage Protection	V <sub>VN_UVP</sub>		--	80%	--	VN
Output Under Voltage Protection Delay Time	t <sub>VN_UVP</sub>		--	40	--	ms
Output Short Circuit Protection	V <sub>VN_SCP</sub>		--	40%	--	VN
Output Short Circuit Protection Delay Time	t <sub>VN_SCP</sub>		--	20	--	us
<b>VPOS LDO</b>						
VPOS Output Voltage Range	V <sub>VPOS</sub>	0.22V/step	7.04	--	15.06	V
VPOS Output Voltage Accuracy	V <sub>VPOS_A</sub>		-2	--	+2	%
VPOS Soft-start Time	t <sub>SS_VPOS</sub>	Sets by SS_TIME	3	--	6	ms
VPOS Current Limit	I <sub>VPOS_OCP</sub>		350	--	--	mA
Line Regulation		VIN=2.9V~5.5V, Load=0mA	--	0.1	--	%/V
Load Regulation		VIN=3.7V, Load=0mA~320mA	--	0.02	--	%/mA
Output Under Voltage Protection	V <sub>VPOS_UVP</sub>		--	80%	--	VPOS
Output Under Voltage Protection Delay Time	t <sub>VPOS_UVP</sub>		--	40	--	ms
Output Short Circuit Protection	V <sub>VPOS_SCP</sub>		--	40%	--	VPOS
Output Short Circuit Protection Delay Time	t <sub>VPOS_SCP</sub>		--	20	--	us
<b>VNEG LDO</b>						
VNEG Output Voltage Range	V <sub>VNEG</sub>	0.22V/step	-15.06	--	-7.04	V
VNEG Output Voltage Accuracy	V <sub>VNEG_A</sub>		-2	--	+2	%
VNEG Soft-start Time	t <sub>SS_VNEG</sub>	Sets by SS_TIME	3	--	6	ms
VNEG Current Limit	I <sub>VNEG_OCP</sub>		350	--	--	mA
Line Regulation		VIN=2.9V~5.5V, Load=0mA	--	0.1	--	%/V
Load Regulation		VIN=3.7V, Load=0mA~320mA	--	0.02	--	%/mA
Output Under Voltage Protection	V <sub>VNEG_UVP</sub>		--	80%	--	VNEG
Output Under Voltage Protection Delay Time	t <sub>VNEG_UVP</sub>		--	40	--	ms
Output Short Circuit Protection	V <sub>VNEG_SCP</sub>		--	40%	--	VNEG
Output Short Circuit Protection Delay Time	t <sub>VNEG_SCP</sub>		--	20	--	us

## Electrical Characteristics (Continued)

( $V_{IN}=3.7V$ , typical values are at  $T_A=25^{\circ}C$ , unless otherwise specified.)

Parameter	Symbol	Conditions	Min	Typ	Max	Unit
<b>VCOM Buffer</b>						
VCOM Output Voltage Range	$V_{VCOM}$	8-bits DAC	-5	--	0	V
VCOM Output Current Range	$I_{VCOM}$		--	--	30	mA
VCOM Output Voltage Accuracy	$V_{VCOM\_A}$		-1.5		+1.5	%
VCOM_DIS Open Drain N-MOS On-Resistance	$R_{ON\_VCOM\_DIS}$		--	100	--	$\Omega$
Maximum VCOM_DIS Current			--	--	50	mA
<b>Positive Charge Pump (VGH)</b>						
VGH Output Voltage Range	$V_{VGH}$		15	--	30	V
VGH Feedback Voltage	$V_{FBGH}$		1.225	1.25	1.275	V
DRVP Switching Frequency	$F_{DRVP}$		--	100	--	kHz
VGH Delay Time	$t_{DLY\_VGH}$	Sets by SS_TIME	3	--	6	ms
DRVP On-Resistance High	$R_{ON\_DRVP\_H}$		--	5	--	$\Omega$
DRVP On-Resistance LOW	$R_{ON\_DRVP\_L}$		--	3	--	$\Omega$
<b>Negative Charge Pump (VGL)</b>						
VGL Output Voltage Range	$V_{VGL}$		-25	--	-15	V
VGL Feedback Voltage	$V_{FBGL}$		-40	0	+40	mV
DRVN Switching Frequency	$F_{DRVN}$		--	100	--	kHz
VGL Delay Time	$t_{DLY\_VGL}$	Sets by SS_TIME	3	--	6	ms
DRVN On-Resistance High	$R_{ON\_DRVN\_H}$		--	5	--	$\Omega$
DRVN On-Resistance LOW	$R_{ON\_DRVN\_L}$		--	3	--	$\Omega$
<b>Power Good Function</b>						
PG Open Drain N-MOS On-Resistance	$R_{ON\_PG}$		--	100	--	$\Omega$
<b>I2C Interface</b>						
SDA/SCL Input High Level	$V_{IH\_I2C}$		1.2	--	--	V
SDA/SCL Input Low Level	$V_{IL\_I2C}$		--	--	0.4	V
SCL Clock Frequency	$f_{SCL}$		10	--	400	kHz
<b>Thermal Sensor</b> <sup>(Note 1)</sup>						
ADC Conversion Time	$t_{ADC\_CON}$	From EN Low to High	--	--	10	ms



## Electrical Characteristics (Continued)

( $V_{IN}=3.7V$ , typical values are at  $T_A=25^{\circ}C$ , unless otherwise specified.)

Parameter	Symbol	Conditions	Min	Typ	Max	Unit
Offset	OffsetTMS	Temperature = 25°C	--	1.18	--	V
Maximum Input Level	VTMS_MAX		--	2.25	--	V
Internal Pull Up Resistor	RNTC_UP		--	7.307	--	kΩ
External Linearization Resistor	RLINEAR		--	43	--	kΩ

Note 1: 10kΩ Murata NCP18XH103F03RB thermistor (1%) in parallel with a linearization resistor (43kΩ, 1%) are used at TS pin for panel temperature measurement.

Power On and Power Off Sequence

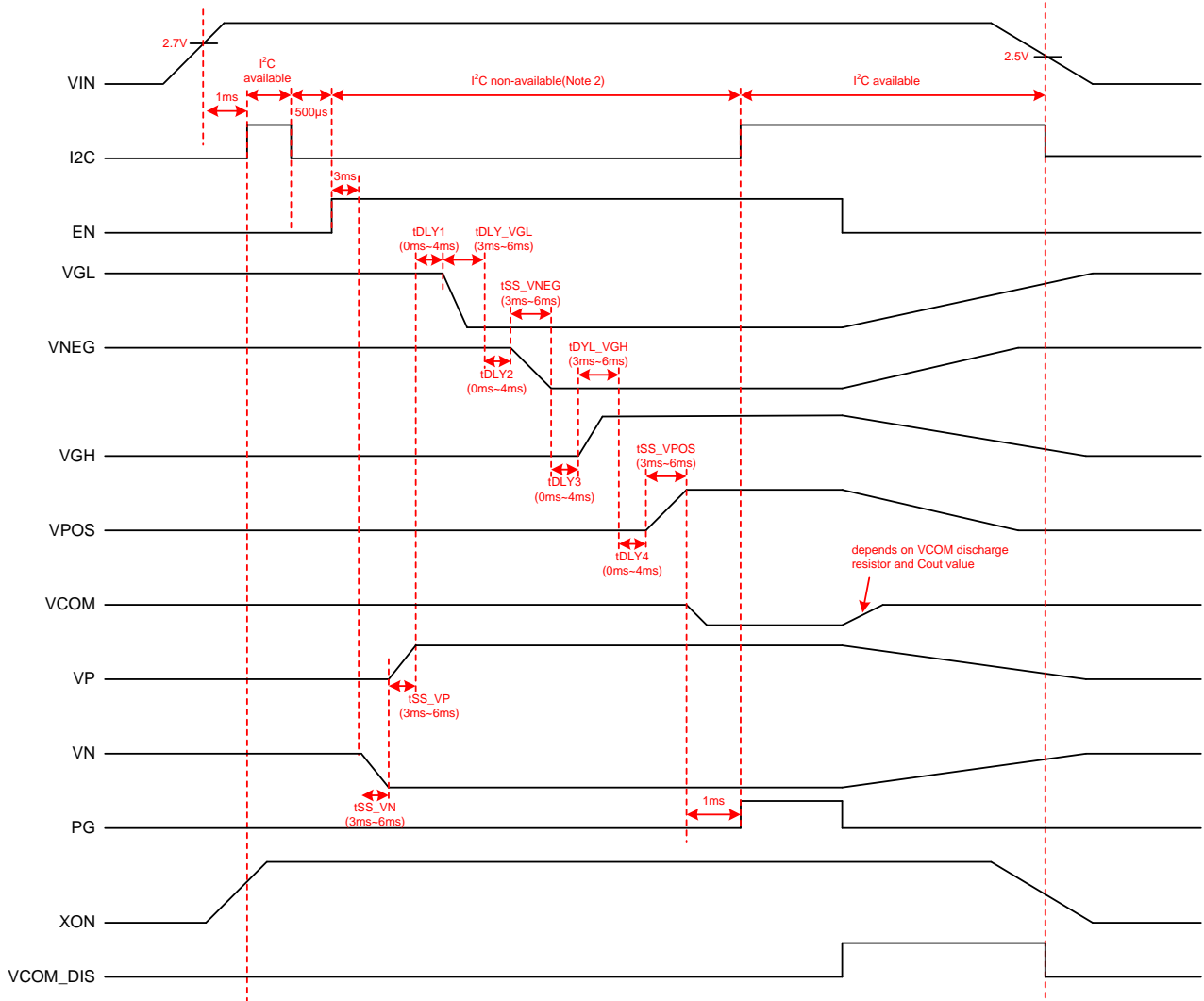

Figure 3. Power On and Power Off Sequence

Note 2: When EN pull high voltage level until PG voltage ready, this period I<sup>2</sup>C function is non-available.

## I2C Address

The IC is a slave-only device and responds to the 7-bit address 18h. D0 is the bit of R/W function, 1 indicating read and 0 indicating write.

D7	D6	D5	D4	D3	D2	D1	D0
0	0	1	1	0	0	0	R/W

## Register Address Map

Register	Address (Hex)	Name	Default Value	Description
0	0x00	TMST_VALUE	N/A	Thermistor value read by ADC
1	0x01	VCOM_SETTING	1000 0000	Voltage setting for VCOM
2	0x02	VPOS & VNEG_SETTING	0000 0000	Voltage setting for VPOS and VNEG
3	0x03	PWRON_DELAY	0000 0000	Power on delay time
4	0x04	NA	0000 0000	Reserved
5	0x05	NA	0000 0000	Reserved
6	0x06	NA	0000 0000	Reserved
7	0x07	NA	0000 0000	Reserved
8	0x08	NA	0000 0000	Reserved
9	0x09	NA	0000 0000	Reserved
10	0x0A	NA	0000 0000	Reserved
11	0x0B	CONTROL_REG1	0000 0000	Soft-start time setting V3P3 switch control
12	0x0C	CONTROL_REG2	0000 0000	I2C read pointer control Converter current limit setting

## THERMISTOR READOUT (TMST\_VALUE)

Address – 0x00h

Data Bit	D7	D6	D5	D4	D3	D2	D1	D0
Field Name	TMST_VALUE [7:0]							
Read/Write	R	R	R	R	R	R	R	R
Reset Value	NA	NA	NA	NA	NA	NA	NA	NA

TMST_VALUE	Temperature	TMST_VALUE	Temperature	TMST_VALUE	Temperature
80H~F5H	< -10°C	00H	0°C	....	....
F6H	-10°C	01H	1°C	....	....
F7H	-9°C	02H	2°C	....	....
F8H	-8°C	03H	3°C	....	....
F9H	-7°C	04H	4°C	....	....
FAH	-6°C	05H	5°C	4CH	76°C
FBH	-5°C	06H	6°C	4DH	77°C
FCH	-4°C	07H	7°C	4EH	78°C
FDH	-3°C	08H	8°C	4FH	79°C
FEH	-2°C	09H	9°C	50H	80°C
FFH	-1°C	0AH	10°C	51H	81°C
		0BH	11°C	52H	82°C
		0CH	12°C	53H	83°C
		0DH	13°C	54H	84°C
		0EH	14°C	55H	85°C
		0FH	15°C	56H~EFH	> 85°C

### VCOM Output Voltage (VCOM\_SEETING)

Address – 0x01h

Data Bit	D7	D6	D5	D4	D3	D2	D1	D0
Field Name	VCOM_SETTING [7:0]							
Read/Write	R/W	R/W	R/W	R/W	R/W	R/W	R/W	R/W
Reset Value	1	0	0	0	0	0	0	0

Name	Description
VCOM_SEETING [7:0]	<p>VCOM voltage setting.</p> <p><math>V_{COM} = 0V + [(-5/255) * N]V</math>, N=0~255</p> <p><b>Default: -2.5098V</b></p>

### VPOS and VNEG Output Voltage (VPOS and VNEG\_SETTING)

Address – 0x02h

Data Bit	D7	D6	D5	D4	D3	D2	D1	D0
Field Name	Not Used		VPOS and VNEG_SETTING [5:0]					
Read/Write	R	R	R/W	R/W	R/W	R/W	R/W	R/W
Reset Value	NA	NA	0	0	0	0	0	0

Register Value	VPOS(VNEG)	Register Value	VPOS(VNEG)	Register Value	VPOS(VNEG)
00H	7.04V(-7.04V)	10H	9.71V(-9.71V)	1DH	12.61V(-12.61V)
01H~04H	7.04V(-7.04V)	11H	9.94V(-9.94V)	1EH	12.83V(-12.83V)
05H	7.26V(-7.26V)	12H	10.16V(-10.16V)	1FH	13.05V(-13.05V)
06H	7.49V(-7.49V)	13H	10.38V(-10.38V)	20H	13.28V(-13.28V)
07H	7.71V(-7.71V)	14H	10.60V(-10.60V)	21H	13.50V(-13.50V)
08H	7.93V(-7.93V)	15H	10.83V(-10.83V)	22H	13.72V(-13.72V)
09H	8.15V(-8.15V)	16H	11.05V(-11.05V)	23H	13.94V(-13.94V)
0AH	8.38V(-8.38V)	17H	11.27V(-11.27V)	24H	14.17V(-14.17V)
0BH	8.60V(-8.60V)	18H	11.49V(-11.49V)	25H	14.39V(-14.39V)
0CH	8.82V(-8.82V)	19H	11.72V(-11.72V)	26H	14.61V(-14.61V)
0DH	9.04V(-9.04V)	1AH	11.94V(-11.94V)	27H	14.83V(-14.83V)
0EH	9.27V(-9.27V)	1BH	12.16V(-12.16V)	28H	15.06V(-15.06V)
0FH	9.49V(-9.49V)	1CH	12.38V(-12.38V)	29H~3FH	15.06V(-15.06V)

Power On Delay Time (tDLY1~tDLY4)  
Address – 0x03h

Data Bit	D7	D6	D5	D4	D3	D2	D1	D0
Field Name	tDLY4		tDLY3		tDLY2		tDLY1	
Read/Write	R/W	R/W	R/W	R/W	R/W	R/W	R/W	R/W
Reset Value	0	0	0	0	0	0	0	0

Name	Description
tDLY1 [1:0]	VGL power on soft start delay time setting. <b>00: 0ms, 01: 1ms, 10: 2ms, 11: 4ms</b> <b>Default: 0ms</b>
tDLY2 [3:2]	VNEG power on soft start delay time setting. <b>00: 0ms, 01: 1ms, 10: 2ms, 11: 4ms</b> <b>Default: 0ms</b>
tDLY3 [5:4]	VGH power on soft start delay time setting. <b>00: 0ms, 01: 1ms, 10: 2ms, 11: 4ms</b> <b>Default: 0ms</b>
tDLY4 [7:6]	VPOS power on soft start delay time setting. <b>00: 0ms, 01: 1ms, 10: 2ms, 11: 4ms</b> <b>Default: 0ms</b>

CONTROL REG1 (SS\_TIME, V3P3\_EN)

Address – 0x0Bh

Data Bit	D7	D6	D5	D4	D3	D2	D1	D0
Field Name	SS_TIME [1:0]		Not Used				V3P3_EN	Not Used
Read/Write	R/W	R/W	R	R	R	R	R/W	R
Reset Value	0	0	NA	NA	NA	NA	0	0

Name	Description
SS_TIME [1:0]	PMIC soft start time setting. <b>00: 3ms, 01: 4ms, 10: 5ms, 11: 6ms</b> <b>Default: 3ms</b>
V3P3_EN [0]	V3P3 switch control. <b>0: Switch off</b> 1: Switch on <b>Default: Switch off</b>

CONTROL REG2 (FIX\_RD\_PTR, VP\_CL, VN\_CL)

Address – 0x0Ch

Data Bit	D7	D6	D5	D4	D3	D2	D1	D0
Field Name	FIX_RD_PTR	Not Used			VP_CL [1:0]		VN_CL [1:0]	
Read/Write	R/W	R	R	R	R/W	R/W	R/W	R/W
Reset Value	0	NA	NA	NA	0	0	0	0

Name	Description
FIX_RD_PTR [0]	<p>I2C read pointer control.</p> <p><b>0: Read pointer is controlled through I2C</b>            1: Read pointer is fixed to 0x00h</p> <p><b>Default: Read pointer is controlled through I2C</b></p>
VP_CL [1:0]	<p>VP boost converter current limit setting.</p> <p><b>00: 3.5A, 01: 4A, 10: 4.5A, 11: 5A</b></p> <p><b>Default: 3.5A</b></p>
VN_CL [1:0]	<p>VN buck-boost converter current limit setting.</p> <p><b>00: 3.5A, 01: 4A, 10: 4.5A, 11: 5A</b></p> <p><b>Default: 3.5A</b></p>



## Application Information

The FP9931 offers a compact power supply solution to provide all voltages required by EPD panels. The FP9931 includes 2 high performance DC-DC converters with LDO, one is for positive voltage (VP/VPOS) and the other is for negative voltage (VN/VNEG) used by EPD drivers, a VCOM buffer (unity-gain OPA), a positive charge pump (VGH) and a negative charge pump (VGL) to provide adjustable regulated output voltages.

The FP9931 provides precise temperature measurement function to monitor the panel temperature during operation.

### Under Voltage Lockout (UVLO)

The UVLO circuitry compares the input voltage, VIN with UVLO threshold (2.7V rising, 2.5V falling) to ensure the VIN is enough to wakeup IC on normal operation. The hysteresis of 200mV prevents IC shutdown from VIN noises or transients.

### Current-Mode Boost Converter (VP/VPOS)

The VP is generated from a high efficiency PWM boost converter operating with current-mode control. PWM switching frequency is fixed on 1.0MHz. During the on-period, TON, the N-MOSFET connects one end of the inductor to ground, therefore increasing the inductor current. However the N-MOSFET turns off and transfer to off-period, the inductor switching node, LXP, will be charged to output voltage by the inductor current. The freewheeling diode turns on and the inductor current flows to the output capacitor.

VPOS is a gated output from the VP by used positive voltage LDO and output voltage can be set by I2C with an output voltage range of 7V to 15V, adjustable in 220mV steps.

### Current-Mode Buck-Boost Converter (VN/VNEG)

The VN is generated from a high efficiency PWM buckboost converter operating with current-mode control. PWM switching frequency is fixed on 1.0MHz. During the on-period, TON, the P-MOSFET connects one end of the inductor to VIN, therefore increasing the inductor current. However the P-MOSFET turns off and transfer to off-period, the inductor switching node, LXN, will be charged to output voltage by the inductor current. The freewheeling diode turns on and the inductor current flows to the output capacitor.

VNEG is a gated output from the VN by used negative voltage LDO and output voltage can be set by I2C with an output voltage range of -7V to -15V, adjustable in 220mV steps.

### Positive Charge Pump (VGH)

VGH is supplied by a positive charge-pump circuit that is powered by VP. VGH voltage can be set by external resistor with an output voltage range of 15V to 30V.

$$VGH(V) = \left( \frac{R1}{R2} + 1 \right) * 1.25$$

### Negative Charge Pump (VGL)

VGL is supplied by a negative charge pump that powered by VN. VGL voltage can be set by external resistor with an output voltage range of -15V to -25V.

$$VGL(V) = -\left( \frac{R3}{R4} \right) * 1.25$$

### Soft-Start

To reduce the inrush current drawn from VIN during start-up, the VP, VPOS, VN, VNEG, VGH, VGL include soft-start feature. Besides they also could adjust soft start time by user's requirement. The soft-start time is controlled by register SS\_TIME.

### V3P3 Power Switch

The integrated power switch is used to connect the 3.3V to the driver and is controlled through the V3P3\_EN register. In power off the switch is automatically turned off and its output is discharged to ground. The default power-up state is OFF. To turn the switch ON, set the V3P3\_EN bit to 1.

### Thermal Monitor

The FP9931 provides circuitry to bias and measure an external NTC to monitor the display panel temperature in a range from -10°C to 85°C with accuracy of ±1°C from 0°C to 45°C. Temperature measurement are triggered by the EN and the last temperature reading is always stored in the TMST\_VALUE register.

## Application Information (Continued)

### VCOM Buffer

VCOM is the output of a negative-output buffer and output voltage can be set by I2C with an output voltage range of 0V to -5V, adjustable in 19.6mV steps.

### Enable Function (EN PIN)

The FP9931 has an EN pin to control all power rails in power on sequence or power off sequence. In a typical application, when the EN pin is high, all power rails are shown in Figure 4.

EN can directly switch states regardless of whether the IC is in the power on sequence state or the power off sequence status without sequence done. See Figure 4.

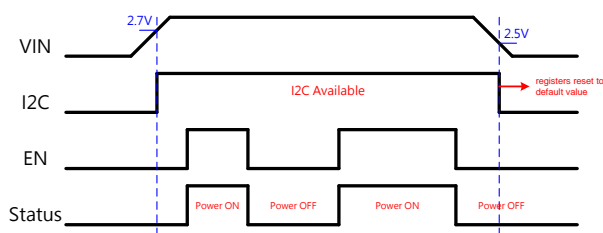

Figure 4. EN Control Status

### Temperature Report

The FP9931 provides temperature report function with thermistor. When the EN pin status is from low to high, the ADC conversion the TS pin voltage to temperature information immediately. The temperature information will be update for each 60s when EN pin is high. See Figure 5.

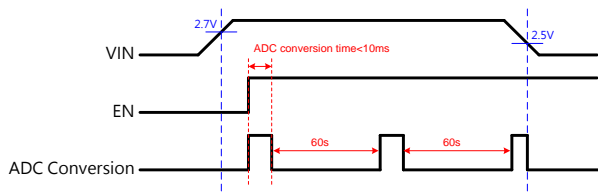

Figure 5. ADC Conversion

### Protection

The FP9931 monitors output voltages and die temperature. The device will take action if operating conditions are outside normal limits when the following is encountered:

- VPOS/VNEG Under Voltage Protection (UVP)
- VPOS/VNEG Short Circuit Protection (SCP)
- IC Over-Temperature Protection (OTP)

It shuts down all power rails and enters shutdown mode. Power rails cannot be re-enabled unless the EN pin has been from low to high. See Figure 6.

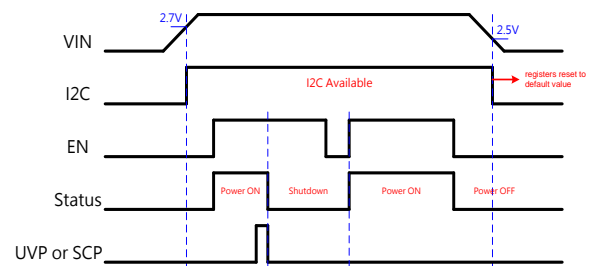

Figure 6. IC Latch and Reset

### Under Voltage Protection (UVP)

If VPOS and VNEG output voltage is between 80% and 40% of the setting voltage and reach 40ms, the IC will shut-down immediately. Once the device re-power on, IC will return to normal operation.

### Short Circuit Protection (SCP)

If VPOS and VNEG output voltage is below 40% of the setting voltage and reach 20us, the IC will shut-down immediately. Once the device re-power on, IC will return to normal operation.

### Over-Temperature Protection

The FP9931 provides Over-Temperature Protection (OTP) to prevent excessive power dissipation from overheating the IC. When the junction temperature exceeds  $T_J=140^{\circ}\text{C}$ , a thermal sensor activates the fault protection, which shuts down the IC, allowing the IC to cool. Once the device re-power on, IC will return to normal operation.

PCB Layout Guide

■ Top  
■ Bottom

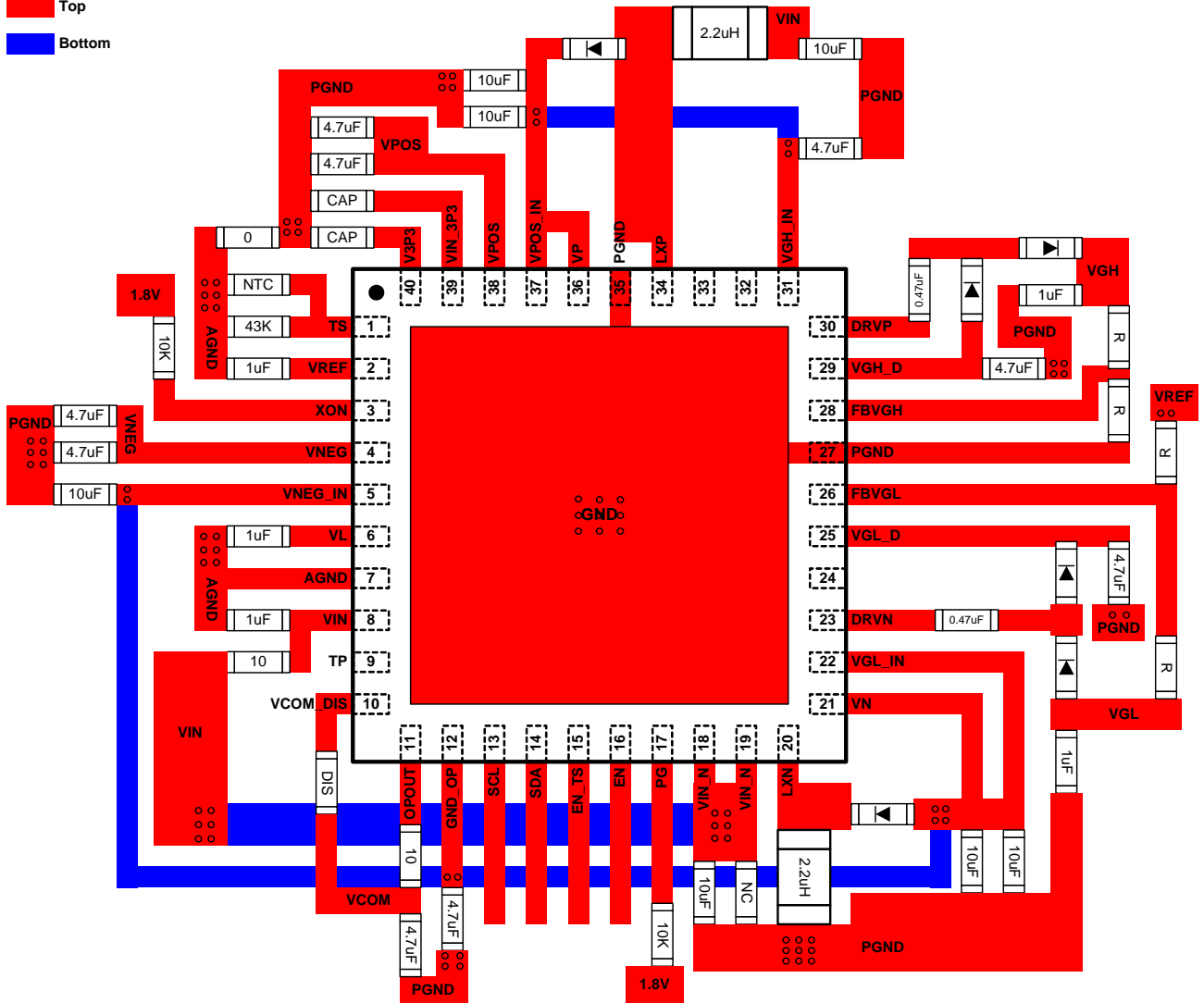

## Outline Information

TQFN-40L 5mm×5mm ( pitch 0.4mm ) Package (Unit: mm)

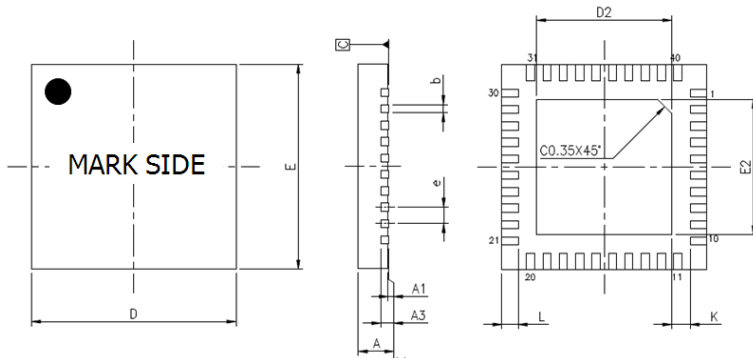

SYMBOLS UNIT	DIMENSION IN MILLIMETER	
	MIN	MAX
A	0.70	0.80
A1	0.00	0.05
A3	0.20 REF	
E	4.95	5.05
D	4.95	5.05
L	0.35	0.45
b	0.15	0.25
K	0.20	-
e	0.40 BSC	
D2	3.20	3.80
E2	3.20	3.80

## Carrier Dimensions

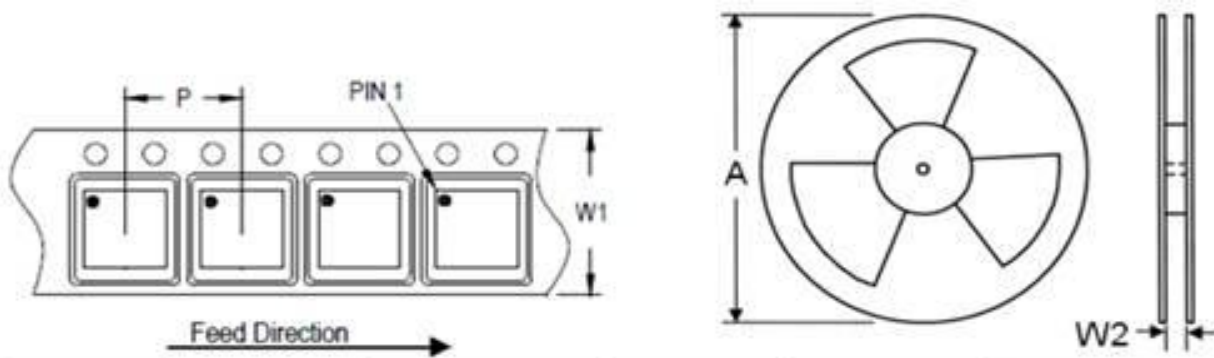

Tape Size (W1) mm	Pocket Pitch (P) mm	Reel Size (A)		Reel Width (W2) mm	Empty Cavity Length mm	Units per Reel
		in	mm			
12	8	13	330	12.4	400~1000	3,000

### Life Support Policy

Fitipower's products are not authorized for use as critical components in life support devices or other medical systems.