

Low-saturation, Low-voltage 1 channels Bi-directional Motor Driver (Micro-actuator Driver)

Description

FP5502 is a micro-actuator driver IC with miniature package (SOT-23-6). It is one channel low voltage bi-directional motor driver IC. The design is optimal for driving different type micro-actuator, such as voice coil motor, piezo-actuator, or other DC motor actuators. It is suitable for camera module application or other portable device.

Features

- Low Voltage Operation (VDD min=1.8V)
- Low Saturation Voltage(Upper Transistor + Low Transistor Residual Voltage; 0.46V typ. at 400mA)
- Low Input Current
- Low Operating Current, Sleep Mode with Zero Current Drain
- Crossover-Current Protection
- High Output Sinking and Driving Capability
- Small, Thin, Highly Reliable Package (SOT-23-6)
- Thermal Shutdown Protection
- RoHS Compliant

Applications

- Voice Coil Motor
- Piezo-actuator
- Camera Module
- Other DC Motor Actuator

Pin Assignments

S6 Package (SOT-23-6)

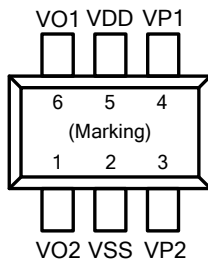
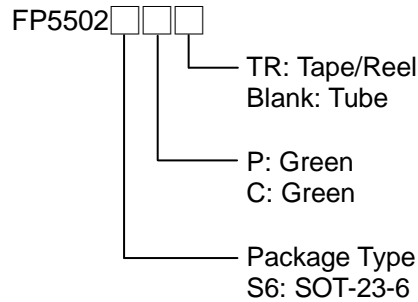

Figure 1. Pin Assignment of FP5502

Ordering Information



SOT-23-6 Marking

Part Number	Product Code
FP5502S6C	C4G

Block Diagram & Application Circuit

Shutter Application:

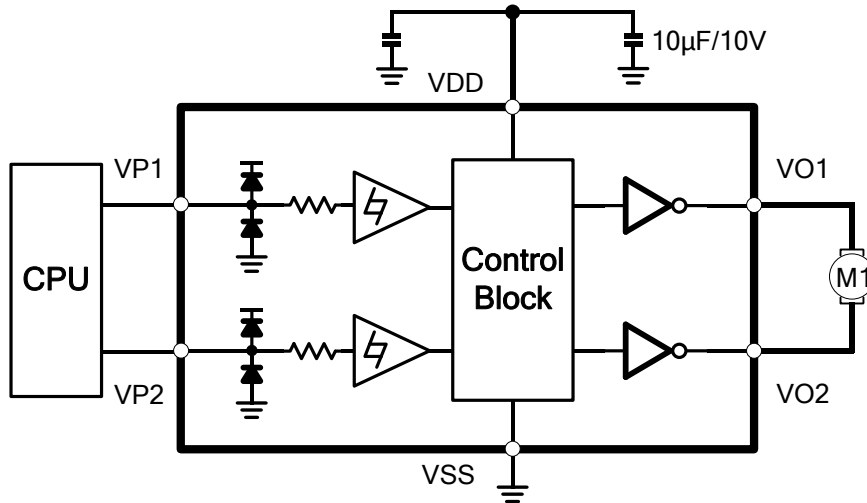

Figure 2. The Block Diagram and Application Circuit of the FP5502

Functional Pin Description

Pin Name	Pin Function
VP2	Input pin which determines driving mode.
VDD	Power supply pin.
VO2	Output sinking / driving pin.
VSS	Ground pin.
VO1	Output sinking / driving pin.
VP1	Input pin which determines driving mode.

Block Diagram

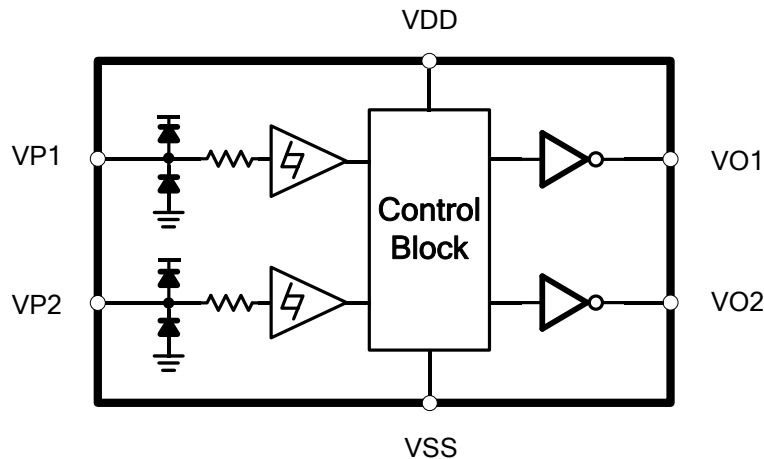

Figure 3. The Block Diagram of the FP5502

Absolute Maximum Ratings

- VDD to GND ----- -0.3V to +5.5V
- VIN and VO to GND ----- -0.3V to +(0.3V +VDD)
- Output Current (Note 1) ----- 0mA to 400mA
- Power Dissipation @ $T_A=25^{\circ}\text{C}$, (P_D)
 - SOT-23-6 ----- 400mW
- Package Thermal Resistance, (θ_{JA}):
 - SOT-23-6 ----- +250°C/W
- Junction Temperature ----- +150°C
- Storage Temperature Range ----- -65°C to +150°C
- Lead Temperature (Soldering, 10sec.) ----- 260°C
- Operating Temperature Range ----- -40°C to +125°C
- ESD (Human Body Model) (Note 2) ----- 4000V

Note 1 : Output current rating may be limited by ambient temperature and heat sinking. Under any set of conditions, do not exceed the specified.

Note 2 : ESD caution: ESD (electrostatic discharge) sensitive device. Electrostatic charges as high as 4000V readily accumulate on the human body and test equipment and can discharge without detection. Although this product features proprietary ESD protection circuitry, permanent damage may occur on devices subjected to high energy electrostatic discharges. Therefore, proper ESD precautions are recommended to avoid performance degradation or loss of functionality.

Electrical Characteristics

(Unless otherwise noted, $T_A=25^\circ\text{C}$ & $V_{DD}=3\text{V}$)

Parameter	Symbol	Conditions	Min	Typ	Max	Unit
Supply Voltage	V_{DD}		1.8	3.0	5.5	V
Supply Current ($I_{DD} + I_S$)	I_{DD0}	$V_{VP1}, V_{VP2}=0\text{V}$	-	0.1	2	μA
	I_{DD1}	$V_{VP1}, V_{VP2}\neq 0\text{V}$	-	0.10	0.2	mA
VP1 / VP2 Input Terminal ($T_J = 25^\circ\text{C}$)						
Input Voltage "H"	V_{IH}	-	$0.5 \cdot V_{DD}$	-	$V_{DD}+0.3$	V
Input Voltage "L"	V_{IL}	-	-0.3	-	$0.2 \cdot V_{DD}$	V
Input Voltage Hysteresis	V_{Hsy}	-	-	0.42	-	V
Input Current "H"	I_{IH}	$V_{IN} = V_{DD}$	-	-	3	μA
Input Current "L"	I_{IL}	$V_{IN} = 0\text{V}$	-	-	3	μA
VO1 / VO2 Output Terminal ($T_J = 25^\circ\text{C}$)						
Output Voltage (upper + lower)	V_{OUT1}	$I_{OUT} = 200\text{mA}$	-	0.22	0.4	V
	V_{OUT2}	$I_{OUT} = 400\text{mA}$	-	0.46	0.7	V
	V_{OUT3}	$V_{DD}=1.8\text{V}, I_{OUT} = 200\text{mA}$	-	0.55	1.0	V
Thermal Protection Circuit						
Protection Temperature	T_{TSD}	$V_{VP1}, V_{VP2}=H$	-	150	-	$^\circ\text{C}$
Temperature Hysteresis	T_{Hsy}	$V_{VP1}, V_{VP2}=H$	-	25	-	$^\circ\text{C}$

Typical Performance Curve

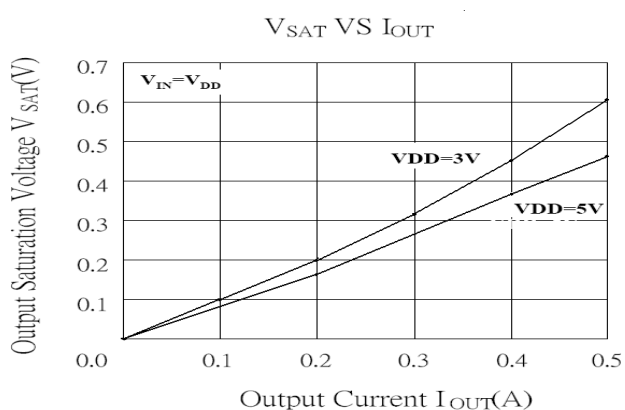

Figure 4a. V_{SAT} VS I_{OUT}

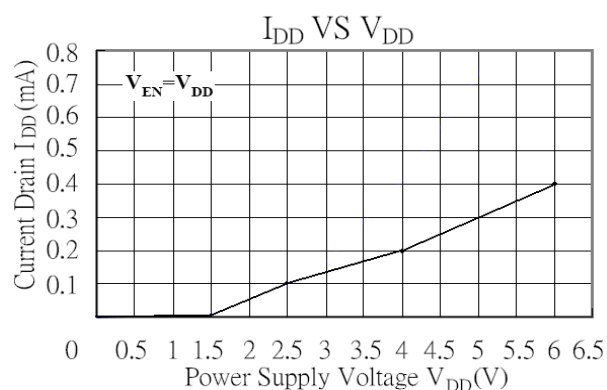

Figure 4b. I_{DD} VS V_{DD}

Truth Table

VP1	VP2	VO1	VO2	Mode
Low	Low	OFF	OFF	Standby
High	Low	High	Low	Forward
Low	High	Low	High	Reverse
High	High	---	---	Keep the previous mode (Forward/ Reverse)

Truth Table Test Wave

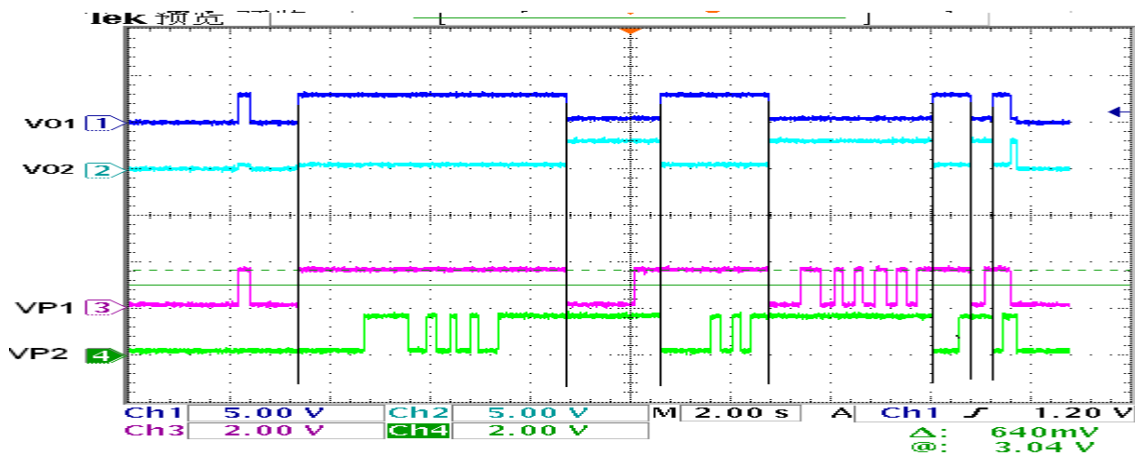

Figure 5. Truth Table test waves

Function Description

Device Operation

FP5502 is a micro-actuator driver IC with miniature package (SOT-23-6). It is one channel low voltage bi-directional motor driver IC. The design is optimal for driving different type micro-actuator, such as voice coil motor, piezo-actuator, or other DC motor actuators. It is suitable for camera module application or other portable device. MOSFET output stages substantially to reduce the voltage drop and the power dissipation of the outputs of the FP5502 compared to typical drivers with bipolar transistors.

Internal circuit protection includes thermal shutdown with hysteresis and crossover current protection. FP5502 is designed for portable applications with a power-off (sleep mode) current of 100nA typical, and an operating voltage of 1.8 to 5.5. FP5502 logic inputs are 3 to 5V logic compatible.

In conditions where the logic supply voltage drops below 1.8V, both the sink and the source voltage drop will increase beyond the specified values. In extreme cases, no power will be delivered to the motors. However, the device will not be damaged.

Sleep Mode

Pulling all inputs to 0.4V or less drives the FP5502 to sleep mode. And it will draw 100nA typical during sleep mode.

Thermal Shutdown

The FP5502 will disable the outputs if the junction temperature reaches 150°C. When it enters thermal shutdown, after the junction temperature drops 15°C, the outputs will be re-enabled

Application Note

The capacitor connected between the output nodes VO1/VO2 will reduce the noise generating by motor when the motor is switched to opposing direction.

The power is dissipated by the IC varies widely with supply voltage, output current and loading. It is important to ensure the application does not exceed the allowable power dissipation of the IC package.

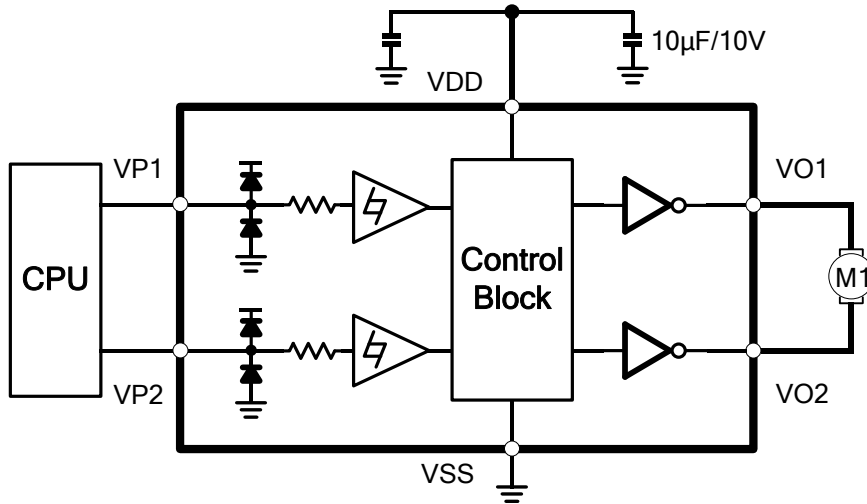

Figure 6. Typical DC Motor Application

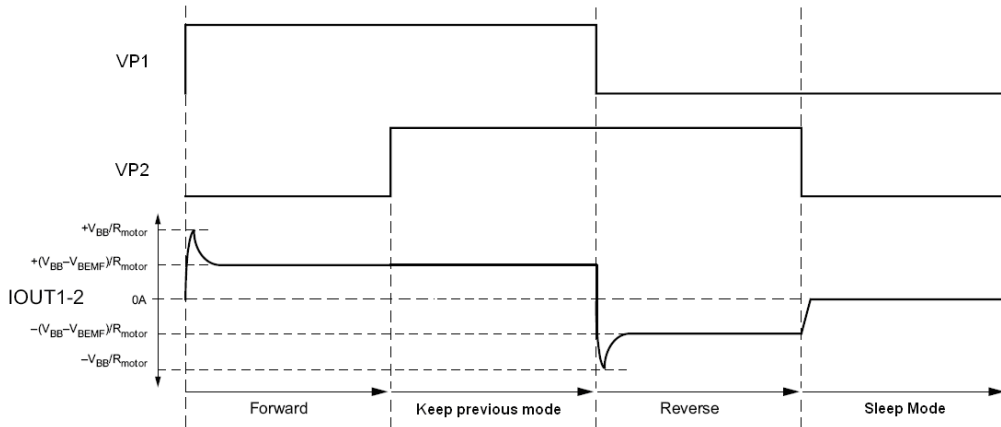
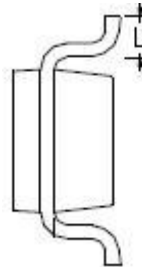
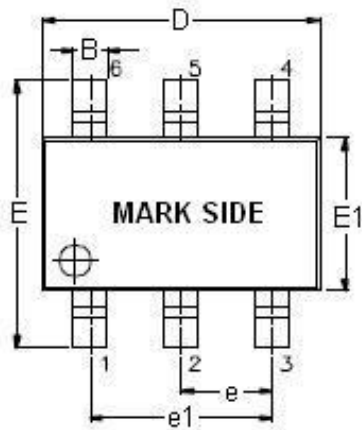

Figure 7. Typical DC motor control application (timing chart)

Outline Information

SOT-23-6 Package (Unit: mm)



SYMBOLS UNIT	DIMENSION IN MILLIMETER	
	MIN	MAX
A	0.90	1.45
A1	0.00	0.15
A2	0.90	1.30
B	0.30	0.50
D	2.80	3.00
E	2.60	3.00
E1	1.50	1.70
e	0.90	1.00
e1	1.80	2.00
L	0.30	0.60

Note : Followed From JEDEC MO-178-C.

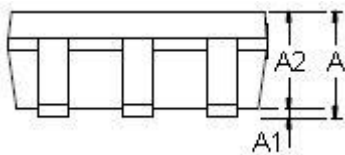

Carrier Dimensions

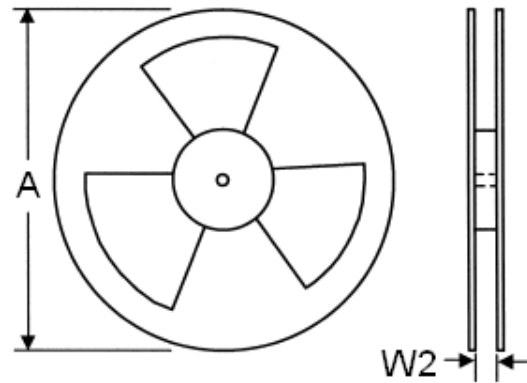
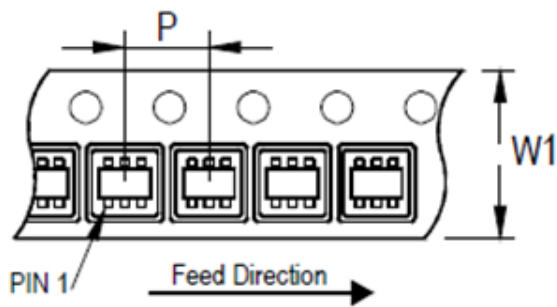

Tape Size (W1) mm	Pocket Pitch (P) mm	Reel Size (A)		Reel Width (W2) mm	Empty Cavity Length mm	Units per Reel
		in	mm			
8	4	7	180	8.4	300~1000	3,000

Life Support Policy

Fitipower's products are not authorized for use as critical components in life support devices or other medical systems.